

产品尺寸图 (DIMENSION)

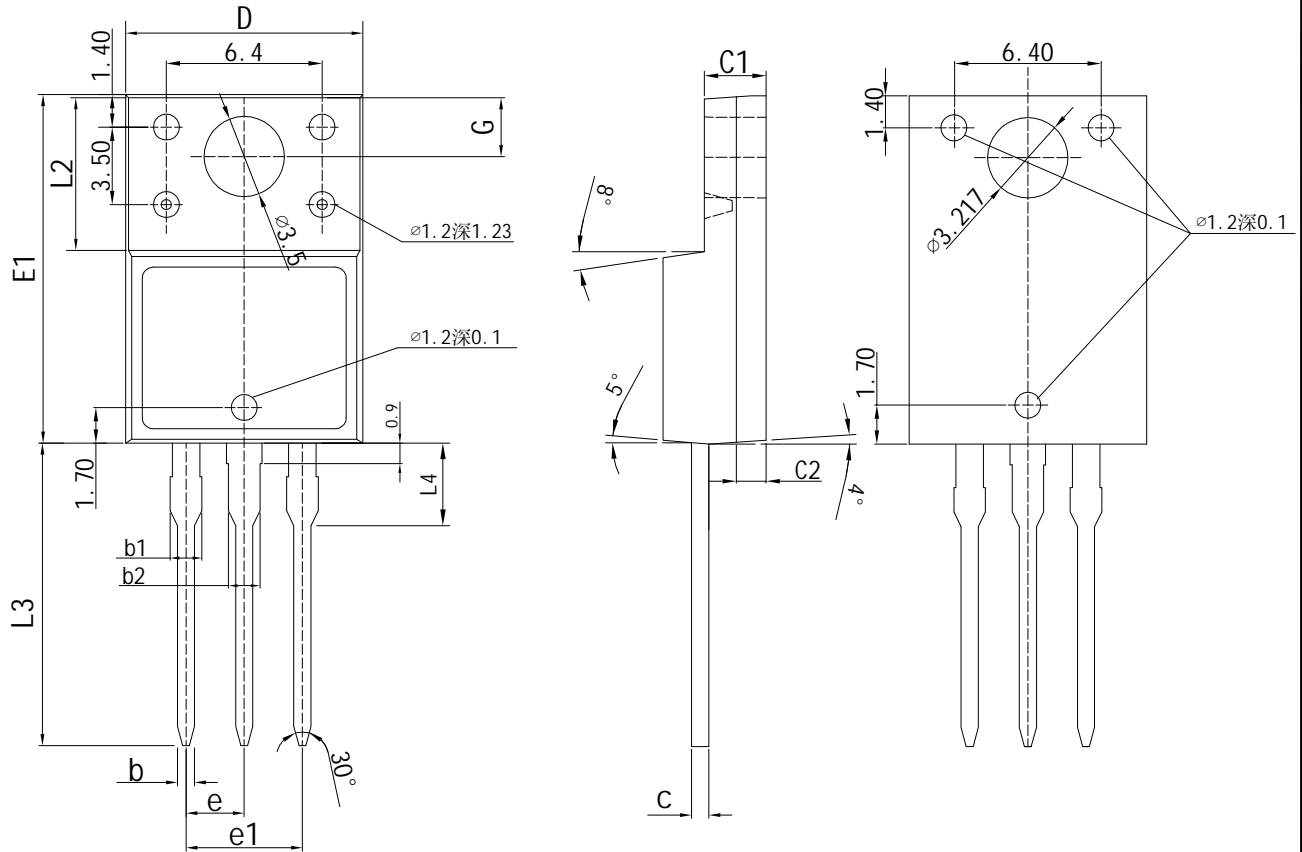

symbol	Dimensions In Millimeters			Dimensions In Inches		
	Min	Nom	Max	Min	Nom	Max
A2	4.400	4.540	4.600	0.1732	0.1787	0.1811
A3	2.450	2.500	2.550	0.0965	0.0984	0.1004
b	0.500	0.600	0.750	0.0197	0.0236	0.0295
b1	1.100	1.300	1.400	0.0433	0.0512	0.0551
b2	1.100	1.300	1.400	0.0433	0.0512	0.0551
c	0.500	0.600	0.700	0.0197	0.0236	0.0276
C1	2.600	2.700	2.800	0.1024	0.1063	0.1102
C2	1.200	1.300	1.400	0.0472	0.0512	0.0551
D	9.900	10.00	10.10	0.3898	0.3937	0.3976
E1	14.90	15.00	15.10	0.5866	0.5906	0.5945
e	2.540TYP			0.1000TYP		
e1	4.880	5.080	5.280	0.1921	0.2000	0.2079
G	2.500	—	3.000	0.0984	—	0.1181
H	27.40	—	28.60	1.0787	—	1.1260
L2	6.700	6.800	6.900	0.2638	0.2677	0.2717
L3	12.50	13.00	13.50	0.4921	0.5118	0.5315
L4	3.600	—	3.800	0.1417	—	0.1496

FSMC

图名 NAME	T0-220F		图号 DWG. NO.	DD0027	SH 1 OF 1
材质 MATERIAL	Cu		REV.	H	
单位 UNITS	mm [INCH]	核准 APPROVE	审核 CHECKED	制图 DRAWN	 第三角
日期 DATE	2017.02.28				
比例 SCALE	N. T. S.				